

## 4-WAY BIVALENT ROTARY MIXING VALVES



V52



V53

### Description

Barberi® motorizable bivalent mixing valves allow the mixing between two fluids (e.g. hot and cold water) to get the desired temperature. The mixing is obtained by using three inlets and one common outlet. They are used in heating and cooling systems, central heating systems, heat generators (wall-mounted boilers, solid fuel generators, heat pumps), systems with stratification buffer storages. The mixing is obtained through a shaped rotor that regulates the passage of the fluids. They can also be used as diverting valves or to increase the return temperature to the generator as anti-condensation devices (in solid fuel or diesel generators).

### Range of articles

- Series V52** Bivalent 4-way mixing valve - Female threaded connections  
**Series V53** Bivalent 4-way mixing valve - Male threaded connections

### Features

Working temperature range (peaks):  
 -20 (see suitable fluids)–130 °C  
 Working temperature range: 0 (no frost)–110 °C  
 Max working pressure: **10 bar**  
 Obturator rotation torque: <5 N·m  
 Rotation angle: **90°**  
 Leakage: <0,1%  
 Suitable fluids: **water for thermal systems, glycol solutions (max 50%)**  
 Threaded connections: **female EN 10226-1, male ISO 228-1**  
 Tests: **EN 12266-1 §A.3**

### Materials

Body: **brass EN 12165 CW617N**  
 Flanges: **brass EN 12165 CW617N**  
 Obturator: **brass EN 12165 CW617N**  
 Gaskets: **EPDM**  
 Graduated plate: **PA6-GF30**  
 Knob: **PA6-GF30**

### Dimensions

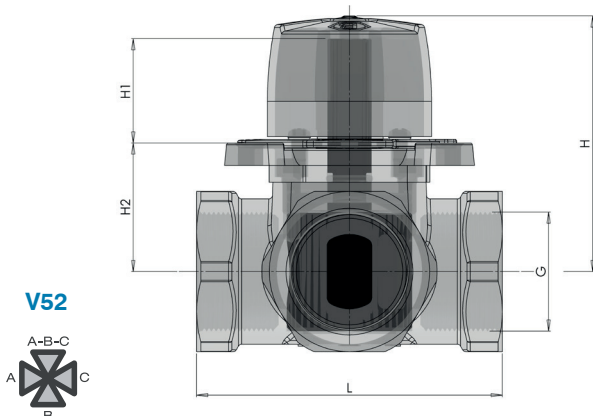

V52

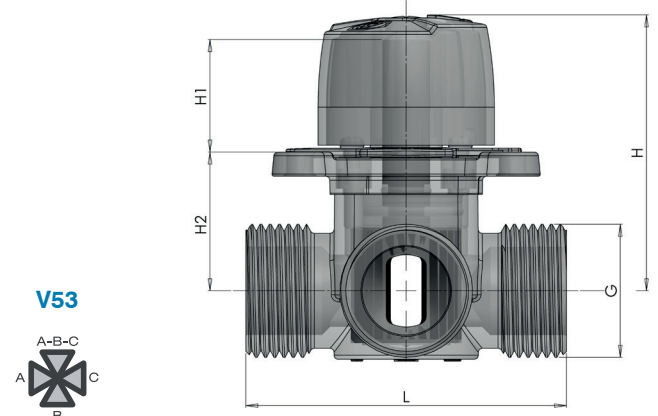

V53

Code	G	Kv	L	H	H1	H2	Weight [g]	N. P/B	N. P/C
V52 020 OMC	Rp 3/4	6,3	82	69	28	35	744	1	10
V52 025 OMI	Rp 1	10	82	69	28	35	820	1	10

Code	G	Kv	L	H	H1	H2	Weight [g]	N. P/B	N. P/C
V53 025 OMC	G 1 M	6,3	80	69	28	35	705	1	10
V53 032 OMI	G 1 1/4 M	10	80	69	28	35	854	1	10

N. P/B: number of pieces in box - N. P/C: number of pieces in carton

Diagrams

Hydraulic characteristics

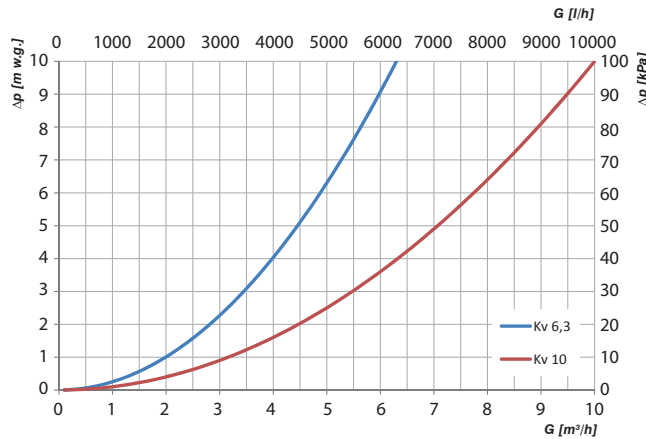

Sizing

Barberi® mixing valves can be sized, by authorized technical personnel, according to one of the following methods:

1) Valve authority “a” (suggested method).

- Let's take into account the part of the circuit that, due to the regulating effect of the valve, works at “variable flow rate”. In this picture, the dashed yellow line puts into evidence the segments, working at variable flow rate, of different hydraulic configurations.

- Let's take into account the design flow rate which flows through the valve with by-pass port fully closed (therefore, all the flow rate passing through the circuit working at “variable flow rate”).

- We calculate the head losses of the circuit “at variable flow rate” ( $\Delta p_c$ ) when the design flow rate passes through it.

- We calculate the valve head losses ( $\Delta p_v$ ) by applying the valve authority formula:

$$a = \Delta p_v / (\Delta p_v + \Delta p_c) \quad \text{therefore} \quad \Delta p_v = (a \cdot \Delta p_c) / (1 - a)$$

$a$  = authority (value decided by the designer)

$\Delta p_v$  = valve head losses (value to be calculated)

$\Delta p_c$  = head losses of the circuit working at “variable flow rate” (value previously calculated by the designer)

According to the type of the system and the use of the mixing valve in mixing or diverting mode, the designer should decide the most appropriate authority value. Common values for the authority are between 0,3 and 0,5. This means we consider the valve head losses between the 30% and 50% of the total head losses of the “variable flow rate” circuit (circuit + valve).

Too low values of authority are synonymous with too large valve and possible difficulty of regulation: the valve can have an effect on the flow rate variation only when approaching the closing position.

Too high values of authority mean small valve with high head losses and, as a consequence, the necessity to select a high head pump. In this case the regulation is fast but at risk of instability: the valve has an immediate effect on the flow rate variation at the beginning of the stroke, but the induced head losses could be excessive, the flow rate too limited and a correct regulation point could be difficult to obtain.

For this reason, a correct value of authority is a compromise between the type of the system and the application mode of the valve (mixing or diverting mode).

- After calculating the  $\Delta p_v$  value, on the hydraulic characteristic diagram we select a valve which, at the design flow rate, shows head losses of a value similar to  $\Delta p_v$ . From the diagram we therefore obtain the Kv of the necessary valve and, as a consequence, the valve size and model.

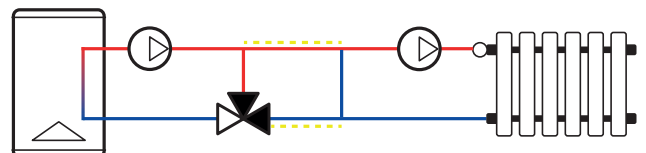
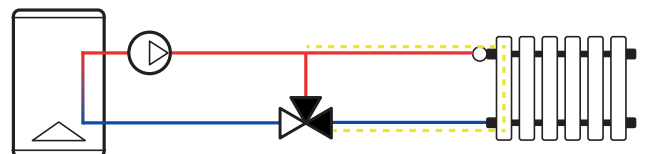
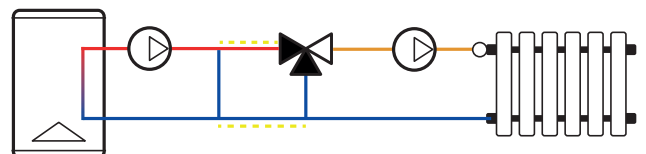
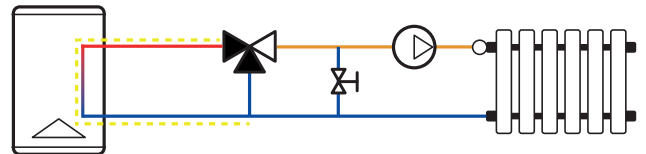
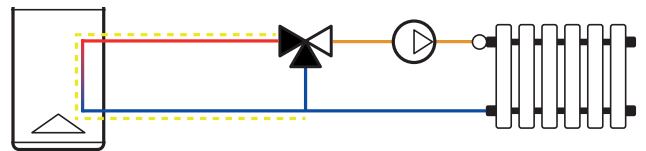

**2) Method of the fluid speed.**

The maximum fluid speed is decided by the designer according to the valve installation point in the system (for example 1,2 m/s for central heating system and 0,5 m/s for secondary circuits). We calculate the valve diameter with the following formula:

$$d = 1000 \cdot \sqrt{[G / (2827 \cdot v)]}$$

d= valve diameter [mm]

G= design flow rate [m³/h]

v= fluid speed [m/s]

The most reliable method is however the valve authority.

**Working way**

Bivalent rotary mixing valves adjust the temperature of the thermal medium by mixing a fluid at higher temperature with another one with lower temperature inside the mixing chamber. The adjustment is performed by a shaped obturator which allows the opening and closing of both the fluid passages. In the factory configuration, according to the rotor position, the common port (marked with the pump symbol) is connected to the other three ports in the following order:

- knob on 0: common port connected to port 1, ports 3 and 2 closed;
- knob on 2: common port connected to ports 1 and 3, port 2 closed;
- knob on 5: port 1 closed, common port connected to port 3, port 2 closed.
- knob on 8: port 1 closed, common port connected to ports 3 and 2.
- knob on 10: ports 1 and 3 closed, common port connected to port 2.

4-way bivalent valves can be used as:

- mixing valves: 3 inlets, 1 outlet. We obtain the temperature regulation of the circuit downstream of the valve (for example: weather compensated temperature adjustment of the flow rate sent to the user; temperature adjustment of the flow rate returning to diesel or solid fuel generators with anti-condensation function);
- diverting valves: 1 inlet, 3 outlets. This working mode is obtained by inverting the flow direction inside the valve: the unique fluid inlet is the port used as mixed water outlet in the mixing valve working mode (for example: loading of a stratification solar buffer storage).

This table shows the use of the valves in mixing (MIX) or diverting mode (DEV). The valves are supplied with the factory configuration called "Standard". Ports can be used according to the other configurations indicated in the table.

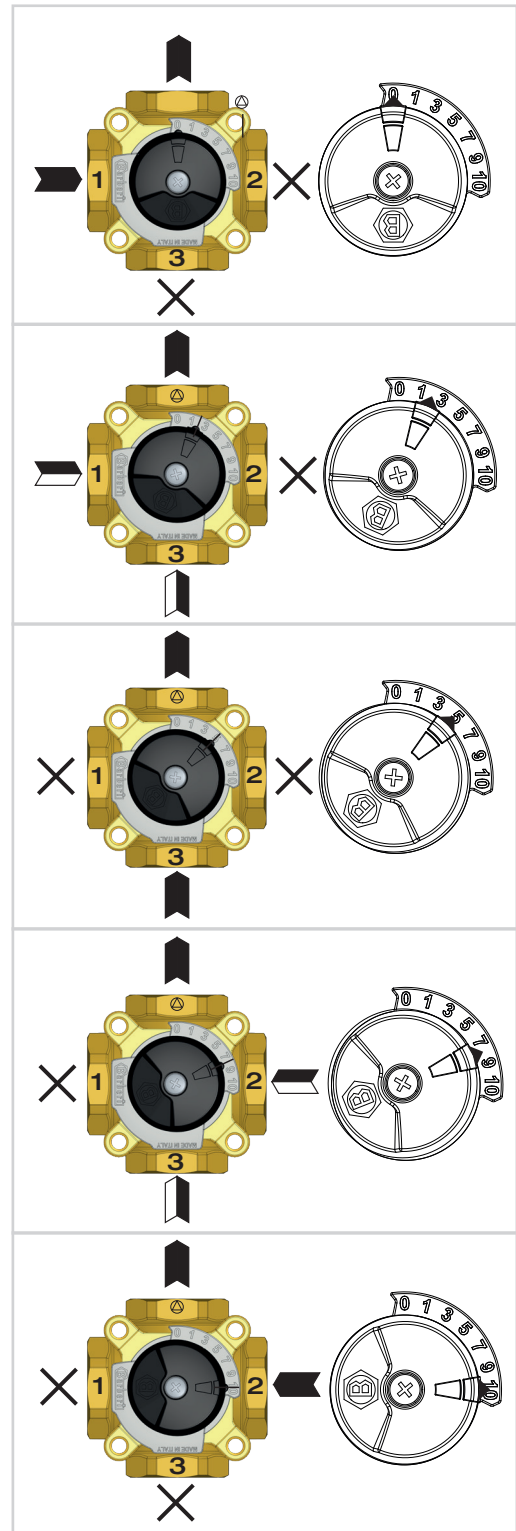
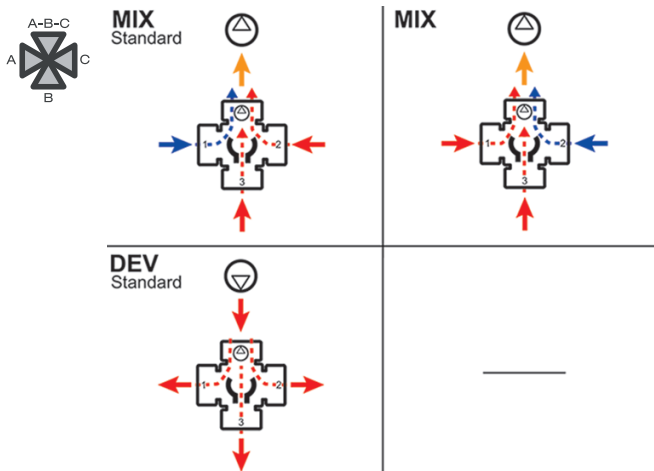

## Configuration

Bivalent mixing valves can be set according to several system configurations. The picture named “Standard” shows the valve in its factory configuration. The other picture shows a further possible way to use the valve ports. In all the pictures, pay attention to the position of the plate with graduated scale and observe the port numeration.

In order to set the valve in a different mode with respect to the “standard” configuration, proceed as follows.

- Disassemble the regulating knob and the plate with graduated scale (fig. 1).
- Choose your own system configuration among the pictures 2 and 3.

- Insert the graduated plate as visible in the chosen diagram, observing the orientation of the plate (clockwise or anticlockwise numbering). Number 10 shows the valve position to obtain the highest value of the mixed water temperature, corresponding to the hot water inlet port fully open and the other ports fully closed. Screw both the plate locking screws.

- If you don't want to motorise the valve, install the knob on the obturator stem (rotor).

- Tighten the locking screw on the knob.

NB: we suggest to modify the valve configuration before installing it on the system to verify the correct functioning of the rotor.

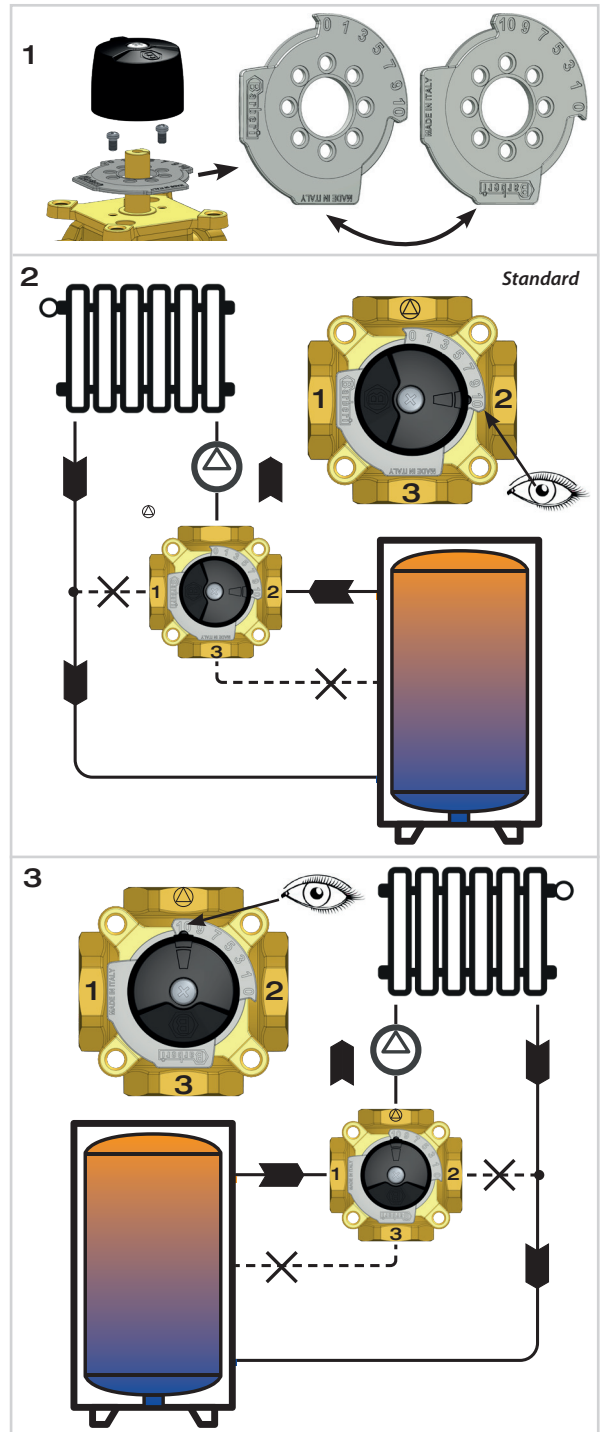

## Installation

Mixing valves are supplied with manual setting knob and locking screw. These valves, in addition to being motorized for automatic regulation, can be configured according to the needs of the system. The motorized valves can be installed according to the following positions.

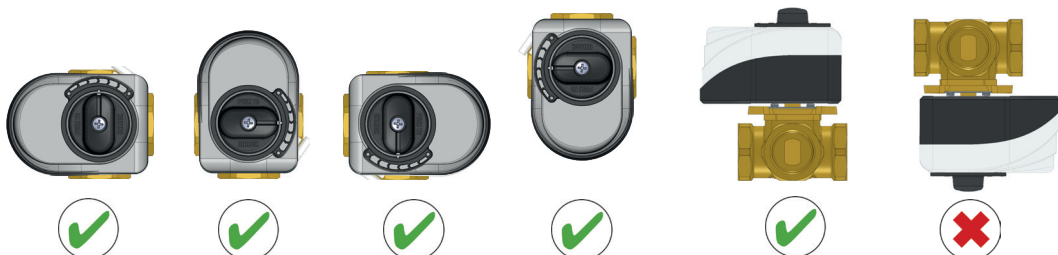

## Actuator installation

To fully exploit the potential of the product, the valve should be motorized by one of the following actuators: 3 point M03, fixed point P27T2, 0(2)-10 V modulating M04. As an example, here following the installation procedure of the M03 actuator.

Components of the M03 actuator (fig. H1): actuator (1), reference ring (2), mixing valve adaptor (3), anti-rotation pin (4), locking screw (5).  
 1) Orient the reference ring (2) as in the upper picture of fig. H2 (arrow dimensions increasing clockwise. For the installation in non "Standard" mode (fig. 1 of the previous page), reverse the ring to have the arrows increasing anticlockwise). Insert the oriented ring (2) into the actuator guides (1).

2) Verify that the indicator on the actuator knob is at half way run (factory setting), aligned with the notch on the reference ring (2). If necessary, restore this configuration by pressing and rotating the actuator knob and then release it (fig. H3).

3) Remove the knob from the valve. Insert the adaptor (3) on the valve stem and screw the antirotation pin (4) (fig. H4).

4) Rotate the valve obturator, acting on the adaptor, positioning the mark on the adaptor (3) on number 5 (corresponding to half way of the mixing valve run, fig. H5).

5) Apply the actuator (1) as in the picture and screw it with the locking screw (5) (fig. H5). This configuration corresponds to the intermediate position of the valve: port 3 fully open, port 1 and 2 closed.

Connect the actuator to a 3 point weather compensated controller, or other device able to manage such actuator, to regulate the flow temperature depending on the outside and room temperatures. Follow the actuator wiring diagram.

Manual mode: the valve, equipped with actuator, can be manually activated by pushing and simultaneously rotating the actuator knob. The actuator is supplied in intermediate position at 45° of rotation (factory setting).

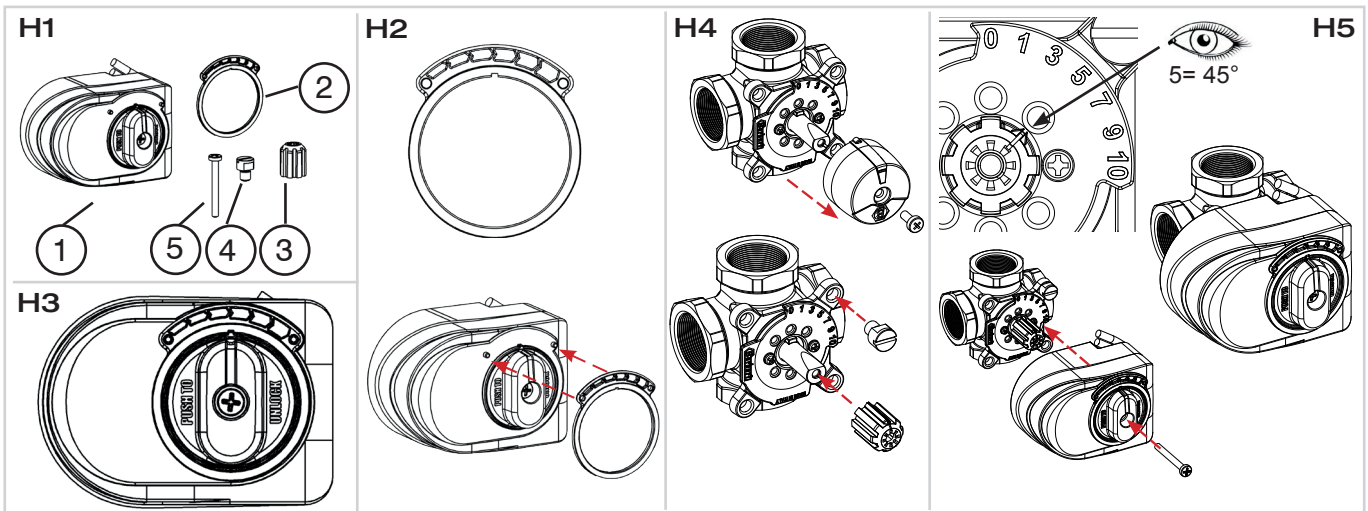

Accessories

## M03.3

Actuator for mixing valves, rotation angle 90°, 3 point regulation. Complete with blocking screw, valve adaptor, anti-rotation pin, 1,5 m integrated cable, auxiliary microswitch (only in 6 pole version)



Torque: **10 N·m**

Protection class: **IP 44**

Frequency: **50 Hz**

Power consumption: **4 VA**

Aux. microswitch contact rating: **6 (1) A**

Code	V	Running time [s]	Nr. poles	Cable [m]		
<b>M03 010 1DA B</b>	230	120	3	1,5	1	16
M03 010 1GA B	230	120	6	1,5	1	16
M03 010 1DB B	230	60	3	1,5	1	16
M03 010 1GB B	230	60	6	1,5	1	16
M03 010 2DA B	24	120	3	1,5	1	16
M03 010 2GA B	24	120	6	1,5	1	16
M03 010 2DB B	24	60	3	1,5	1	16
M03 010 2GB B	24	60	6	1,5	1	16

## M04

Actuator for mixing valves, rotation angle 90°, proportional regulation 0 (2)-10 V. Complete with blocking screw, valve adaptor, anti-rotation pin, 1,95 m integrated cable



Torque: **5 N·m**

Feedback: **0-10 V/4-20 mA**

Protection class: **IP 42**

Frequency: **50 Hz**

Power consumption: **4 VA**

Code	V	Running time [s]	Nr. poles	Cable [m]		
M04 010 3MA B	24	60 - 90 - 120	4	1,95	1	10

## P27T2

Actuator for mixing valves, rotation angle 90°, for 3 point regulation with integrated probe and temperature regulator. Temperature adjustment range 5-95 °C. Complete with blocking screw, mixing valve adaptor, anti-rotation pin, Pt 1000 probe (1,6 m cable), contact probe holder, integrated Shuko electrical plug (1,9 m cable).



Temperature adjustment range: **5-95 °C**

Torque: **6 N·m**

Protection class: **IP 42**

Frequency: **50 Hz**

Power consumption: **1,5 VA**

Code	V	Running time [s]	Nr. poles	Cable [m]		
<b>P27 230 010 T2</b>	230	120	2	1,9	1	10

System diagrams

Use of V52 and V53 as mixing valves

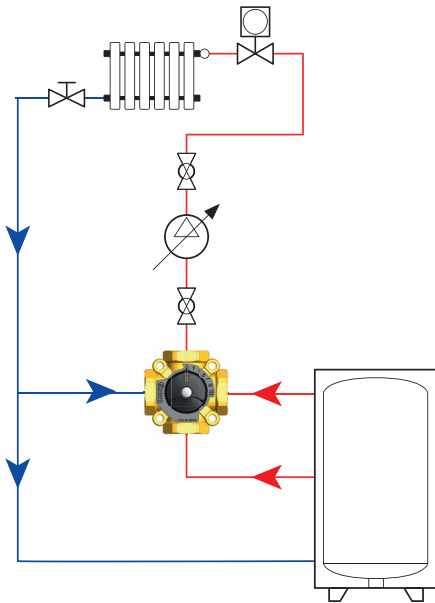

Use of V52 and V53 as diverting valves

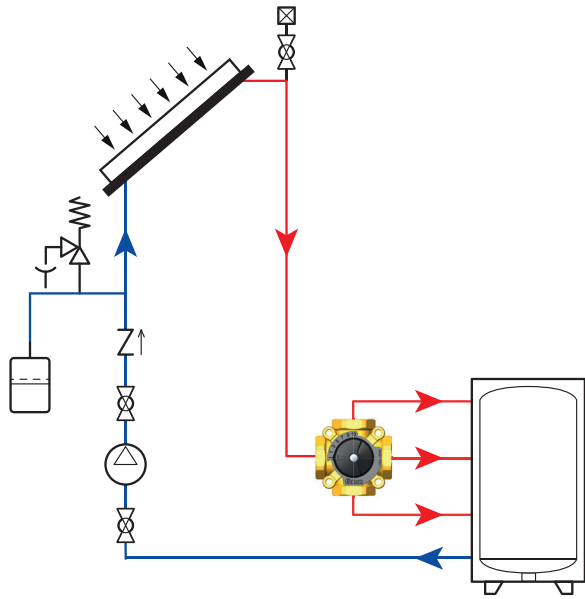

Use of V52 and V52 valves with anti-condensation function

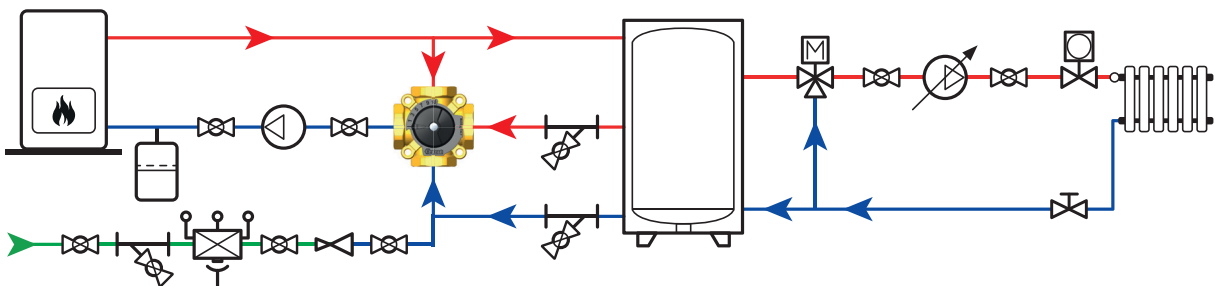

Specifications

**Series V52**

4-way rotary bivalent mixing valve with manual knob. Fitted to be actuated. Threaded connections Rp 3/4 (from Rp 3/4 to Rp 1). Body, closing flange and obturator in brass; EPDM gaskets; graduated plate and knob in ABS. Maximum working pressure 10 bar. Working temperature range 0–110 °C. Obturator rotation torque lower than 5 N·m. Leakage lower than 0,1%. Suitable fluids water for thermal systems, glycol solutions (max 50%).

**Series V53**

4-way rotary bivalent mixing valve with manual knob. Fitted to be actuated. Threaded connections G 1 M (from G 1 to G 1 1/4). Body, closing flange and obturator in brass; EPDM gaskets; graduated plate and knob in ABS. Maximum working pressure 10 bar. Working temperature range 0–110 °C. Obturator rotation torque lower than 5 N·m. Leakage lower than 0,1%. Suitable fluids water for thermal systems, glycol solutions (max 50%).